

# Pioneering Climbing Wall

## Hobbies & Wheels 2006

### Objective

Scouts to build a pioneering based climbing wall structure with minimum supervision. The aim is to give them the satisfaction of building a challenging and fun structure, to give them practice in pioneering skills, and to develop an interest in the art of pioneering.

### Instructions

Construct climbing wall per the attached two diagrams. Spars can be cut as necessary. Spars will have to be sheer lashed to get the necessary lengths (note that no frapping turns are used in this type of sheer lashing).

For the climbing holds, drill 7/16" holes in the plywood. Tap the T-nuts in from the back with a hammer. Fasten the holds with the supplied bolts and Allen keys.

The rope ladder must be secured at both the top and bottom. If time runs short, an extension ladder is available instead, but the rope ladder will be much more impressive and fun for the kids.

The corners of the structure must be pegged to the ground to eliminate any possibility of tipping.

Screws are available in the event that the plywood needs to be secured a little more strongly.

### Usage

Only one kid should be allowed on the climbing surface at once. Scouts should be able to navigate the structure by themselves. Cubs may require a Scout or adult at the top to help them onto the rope ladder. Recommend to initially only allow upwards climbing; "rapelling" down can be tried afterwards.

### Safety Considerations

As the climbing structure is only 16' tall, and is inclined, it does not have the same safety requirements as a commercial climbing wall. These are at least 30' tall and vertical. This structure is no different than climbing trees or small rock walls at camp. Helmets are not required as there is no danger of anything falling from above. An adult must check the structure for soundness before any kids are allowed to climb. Climbing harnesses and rope will be available if it is determined they are needed.

### Materials

Spars, various lengths	Cordless drill
Saw, Swedish, 1	Drill bit, 7/16"
Rope, Manilla, 1/2", for lashing	Climbing holds (with bolts and T-nuts), 20
Plywood, 4' x 8' x 3/4", 2 sheets	Allen key, 2
Hammer, sledge, 5 lbs	Screws, wood, 2"
Hammer	Screwdriver bit, Robertson, red
Stakes (for pegging), 6	Ladder, extension, 24'

### Credit

The original source of the climbing wall itself appears to be long lost. The lashing instructions and diagrams are courtesy of fact sheet 315080 from [www.scoutbase.org.uk](http://www.scoutbase.org.uk)

# Pioneering Climbing Wall Hobbies & Wheels 2006

## Climbing Wall

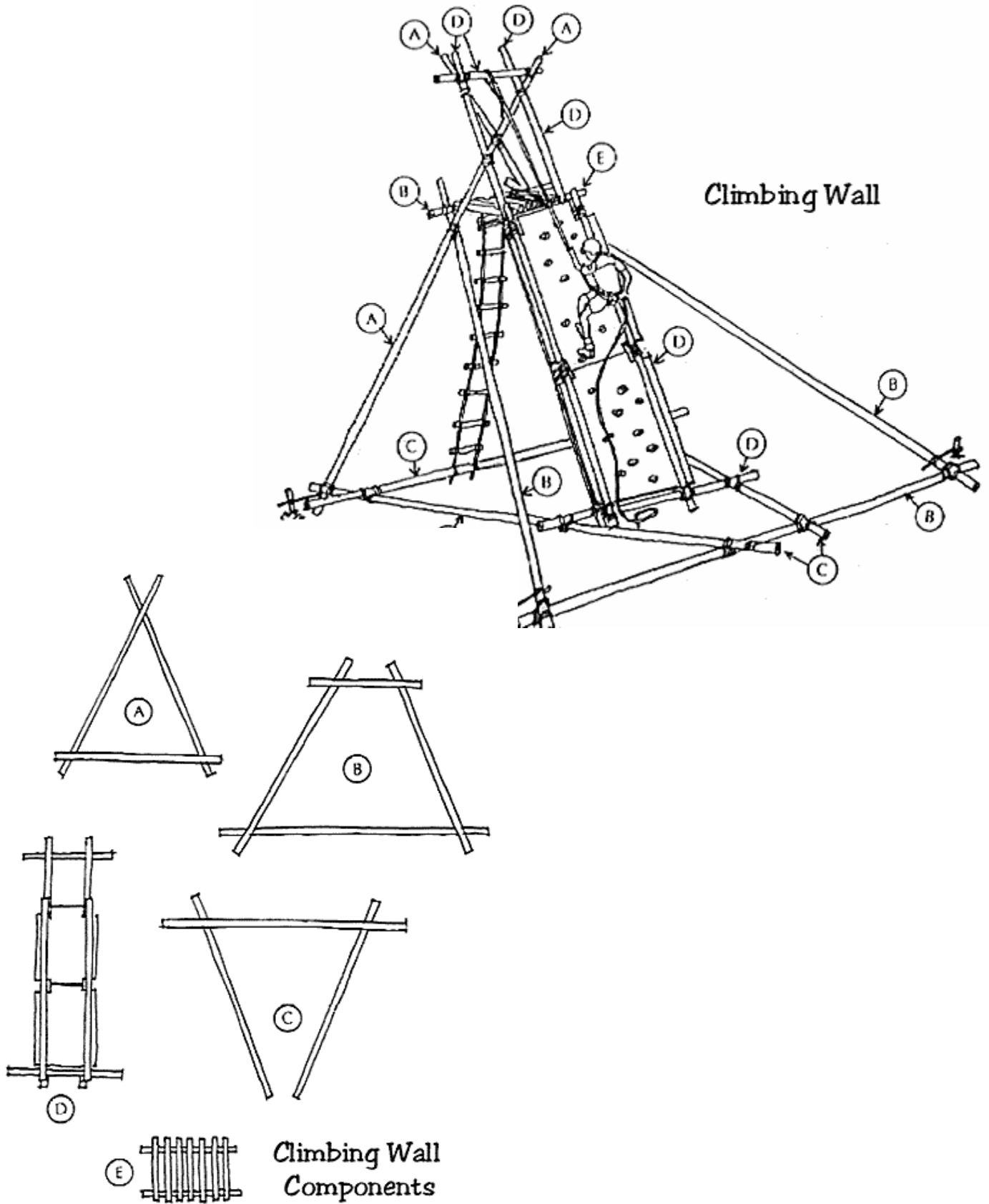

# Pioneering Climbing Wall Hobbies & Wheels 2006

## Ladder Hitch

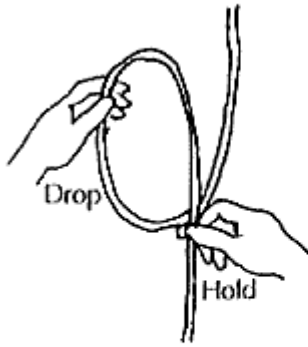

Fig.1



Fig.2

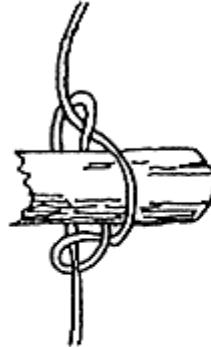

Fig.3

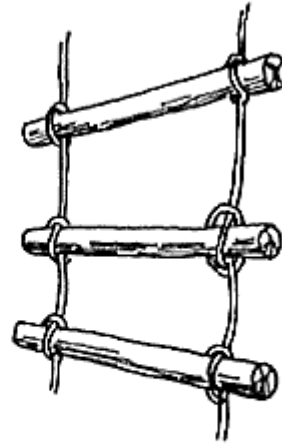

Fig.4

## Ladder Hitch

# Pioneering Climbing Wall Hobbies & Wheels 2006

## Sheer Lashing

The sheer lashing is used for joining two spars to increase the overall length.

It is important to have a good overlap of spars which should be at least a quarter of the length, but better still is an overlap of one third.

Start with a clove or timber hitch around both spars near the end of the overlap.

Continue with eight to ten turns round both spars (or for about 10-15cm).

Finish with a clove hitch around the second spar.

To tighten, insert small wedges inside the turns

Adding a second lashing will strengthen the overlap as, then no movement is possible in any direction.

Courtesy of fact sheet 315080, "Scouting Skills Lashing", on [www.scoutbase.org.uk](http://www.scoutbase.org.uk).

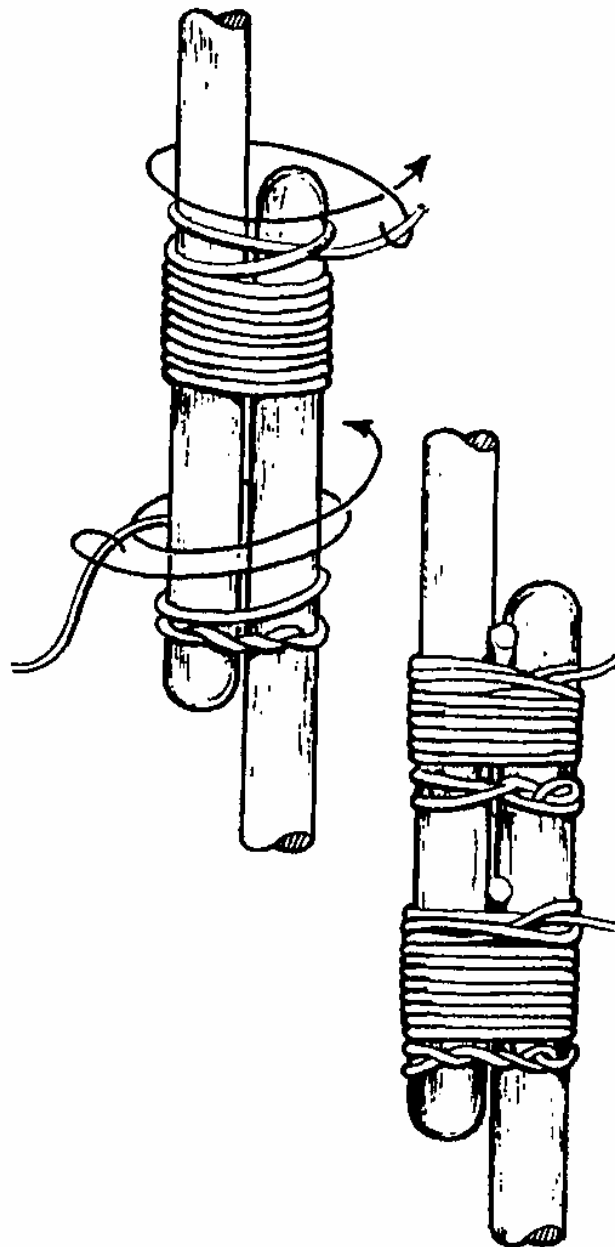

# Pioneering Climbing Wall Hobbies & Wheels 2006

## Square Lashing

A Square Lashing is the most commonly used for pioneering and is used where the spars will try to slide over each other regardless of the angle at which the spars cross

Begin with a clove hitch underneath the spar to be supported. (a)

Wrap the rope first over one spar, then under the other, pulling tight all the time. (b)

On the second time round, go inside the previous turn of rope on top, but outside underneath the spars. (c)

After three turns, apply two frapping turns, which pull on the rope turns already made, making them even tighter. (d)

Finish off with a clove hitch. (e)

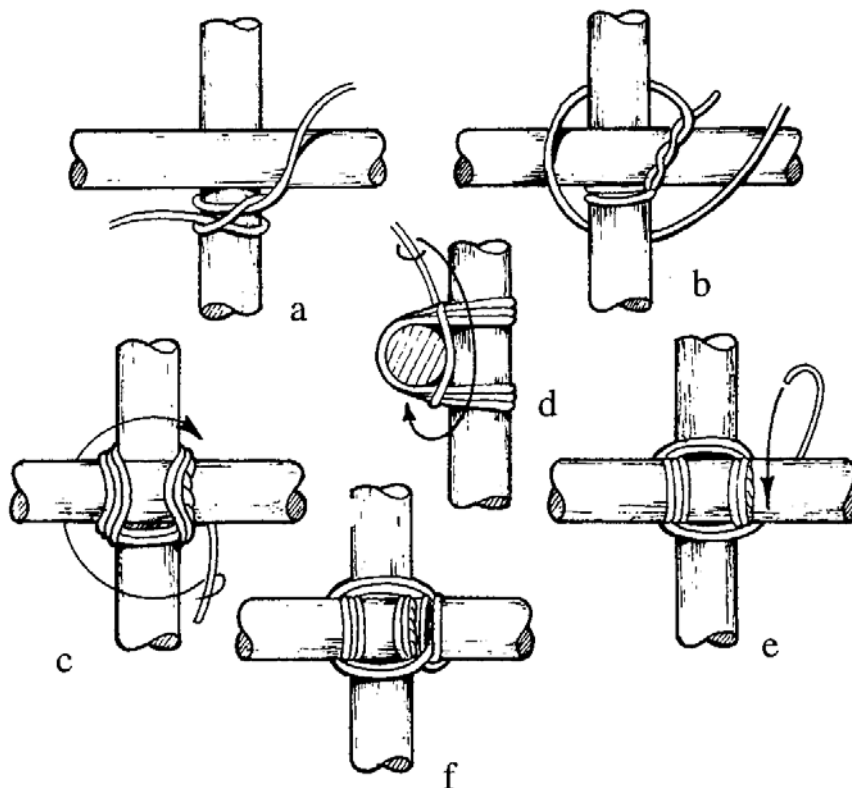

# Pioneering Climbing Wall Hobbies & Wheels 2006

## Diagonal Lashing

A Diagonal Lashing is used where the spars have to be pulled together or when they tend to spring apart from each other. For example the cross-brace of a framework.

Begin with a timber hitch to draw the spars together.

Pull the knot at right angles and wrap the rope three times around the spars, keeping the rope tight all the time.

Wrap three more turns, this time over the timber hitch.

Apply two frapping turns to pull tight the rope turns.

Finish off with a clove hitch.

